

# Energy Efficient Options for Residential Water Heating

Feb 2018

**Ben Schoenbauer, Senior Research Engineer**

Center for Energy and Environment



**In accordance with the Department of Labor and Industry's statute 326.0981, Subd. 11,**

**“This educational offering is recognized by the Minnesota Department of Labor and Industry as satisfying 1.5 hours of credit toward Building Officials and Residential Contractors continuing education requirements.”**

**For additional continuing education approvals, please see your credit tracking card**

# Discover + Deploy

the most effective solutions for a healthy, low-carbon economy

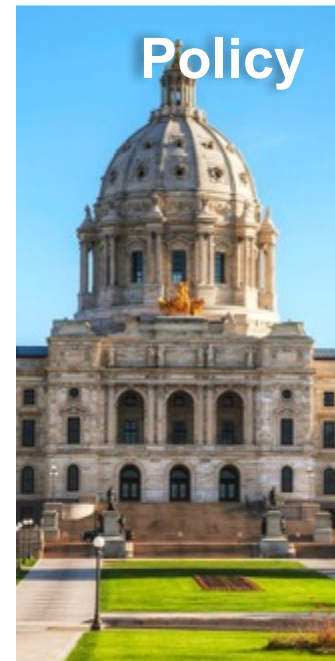

# Acknowledgements

This project was supported in part by a grant from the Minnesota Department of Commerce, Division of Energy Resources through a Conservation Applied Research and Development (CARD) program



# Sponsors and Partners

- NorthernSTAR - A DOE Building America Research Team
- Sustainable Energy Resources for Consumers Grants



- Center for Energy and Environment
- Sustainable Resources Center
- University of Minnesota
- The Energy Conservatory



# Agenda

- Ratings and Standards
- MN Water Heater Use
- Natural Gas Water Heating
- Electric Water Heating
- Distribution
- New Developments in Water Heating

# Minnesota Usage

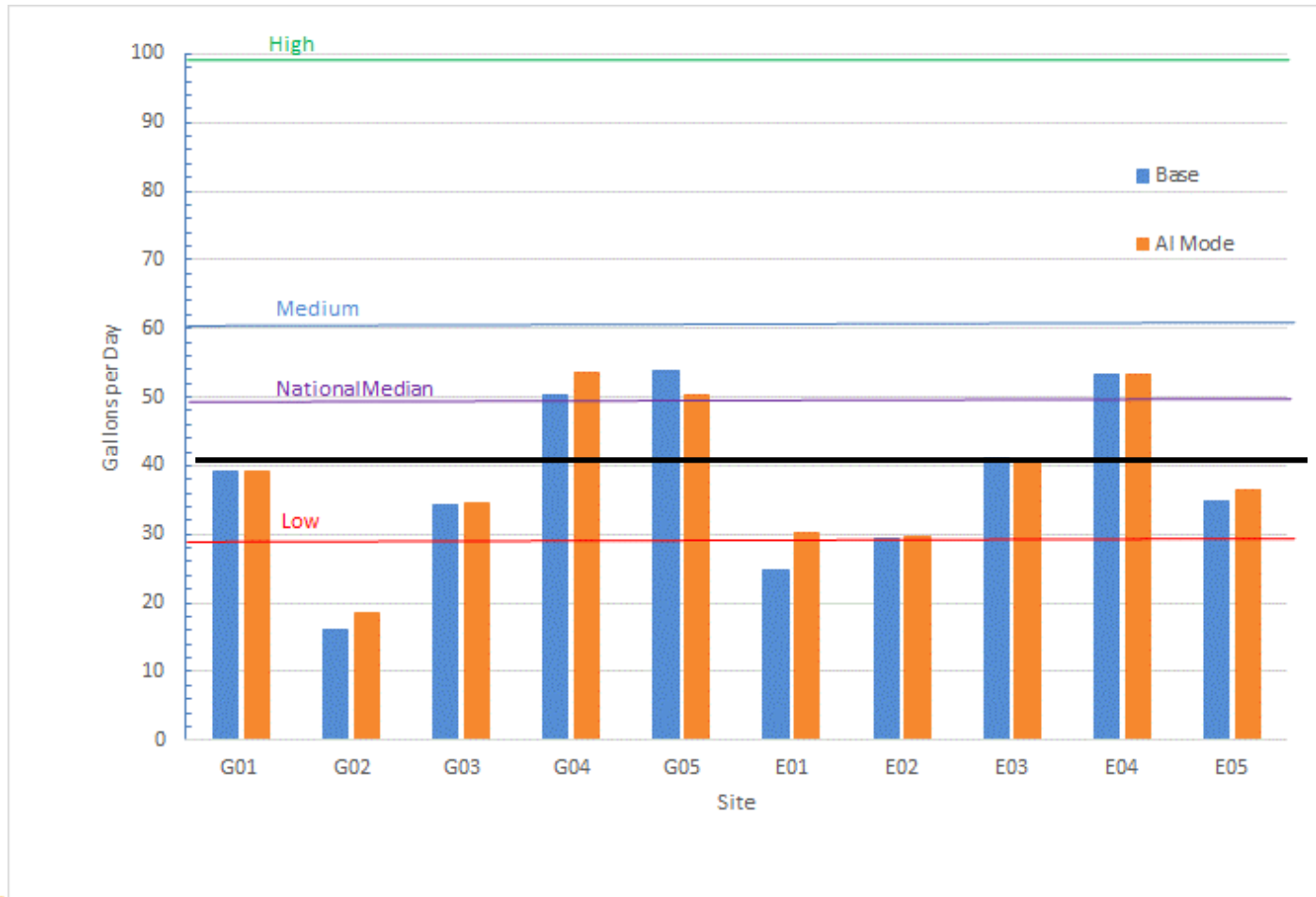

MN  
Average



# Minnesota Usage

Hot Water Use GPD	Hot Water Load therms/yr	Nat. Gas WH Use therms/yr	Nat. Gas WH Cost \$/year	Electric WH Use kWh/yr	Electric WH Cost \$/year
20	42.4	70.7	\$ 57	1242	\$ 99
30	63.6	106.0	\$ 85	1864	\$ 149
40	84.8	141.4	\$ 113	2485	\$ 199
50	106.0	176.7	\$ 141	3107	\$ 249
60	127.2	212.1	\$ 170	3728.	\$ 298
100	212.1	353.4	\$ 283	6214	\$ 497



# DOE Energy Factor Rating

- DOE Passed a new rating method
  - Energy Factor (EF) became Uniform Energy Factor (UEF)
  - Still the same simulated use test
  - Now there are four usage categories instead of one

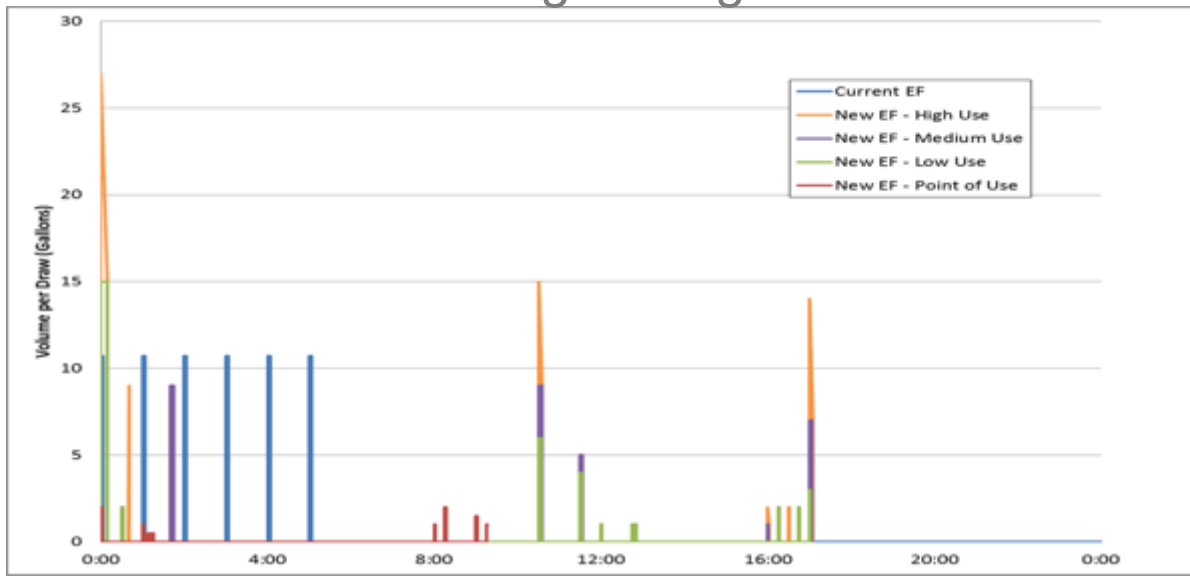



# UEF Process

- UEF test has a capacity test
  - First hour rating
- WH capacity is used to determine the load size
- A hot water profile is drawn from the water heater based on capacity
- During the draws, energy into and out of the water heater is measured
- And UEF is calculated



## UEF Impacts

- UEF should be more representative of field use
- Capacity category can impact UEF rating
- Small changes to UEF ratings of existing systems
- Small changes to the federal minimum ratings



# DOE UEF Rating

Energy Conservation Standards				
Fuel	Type	Rated Storage Volume	Uniform Energy Factor	Energy Factor
Natural Gas	Storage	≥ 20 gal and ≤ 55 gal	0.675 – 0.0015V	0.67 – 0.0019V
Natural Gas	Storage	> 55 gal and ≤ 100 gal	0.8012 – 0.00078V	0.67 – 0.0019V
Fuel Oil	Storage	≤ 50 gal	0.68 – 0.0019V	0.59 – 0.0019V
Electric	Storage	≥ 20 gal and ≤ 55 gal	0.960 – 0.0003V	0.97 – 0.00132V
Electric	Storage	> 55 gal and ≤ 120 gal	2.057 – 0.00113V	0.97 – 0.00132V
Tabletop	Storage	≥ 20 gal and ≤ 100 gal	0.93 – 0.00132V	0.93 – 0.00132V
Natural Gas	Instantaneous	< 2 gal	0.82 – 0.0019V	0.62 – 0.0019V
Electric	Instantaneous	< 2 gal	0.93 – 0.00132V	0.93 – 0.00132V



# Electric Thermal Storage

- Minimum efficiency increased in 2016
- Would require heat pump water heaters for 55 gallons and under
- Waiver process created for demand savings programs
  - This effort was lead in part by MN utilities, municipals, and co-ops

# New Energy Guide Labels

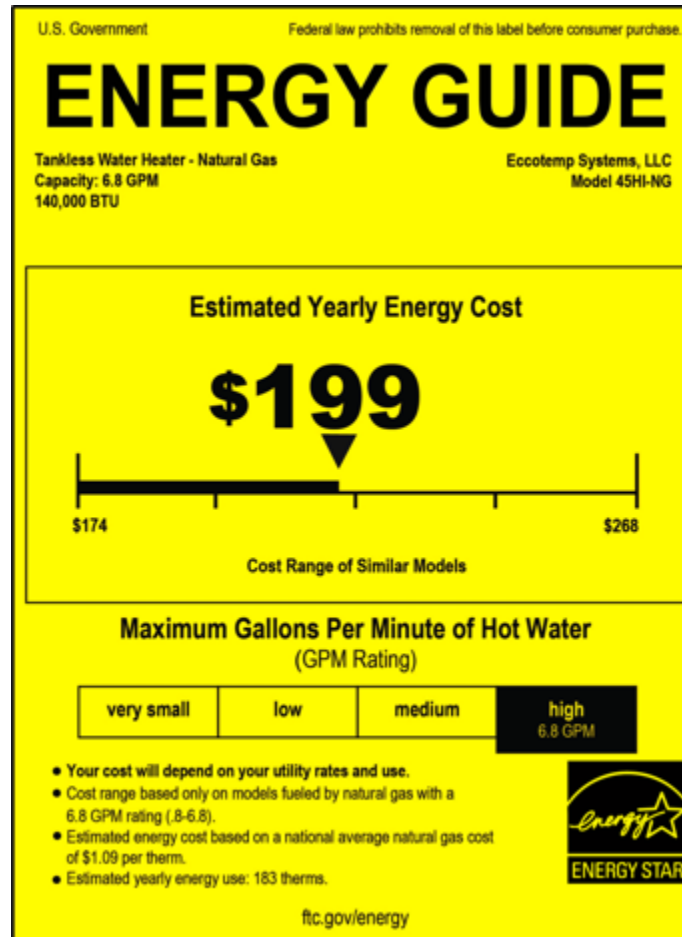



# Water Heating Technologies

- Natural Gas
  - Storage Water Heaters
  - Tankless Water Heaters
  - Hybrid Water Heaters
  - Gas Heat Pump Water Heaters
- Electric
  - Storage Water Heaters
  - Tankless Water Heaters
  - Heat Pump Water Heaters
  - ETS Water Heaters
- Other Retrofit technologies

# Gas Water Heating





# Storage Water Heaters

- Water stored at temperature
- When tank temp drops below certain temp burner fires
- Typically volumes greater than 30 gallons and burners around 40,000 btu/hr for whole house



# Storage Water Heaters

- Types:
  - Natural Draft
  - Power Vent
  - Condensing
- Operation:
  - Quick response
  - Higher stand-by loses
  - Potential to run out of hot



# Hot Water Delivery

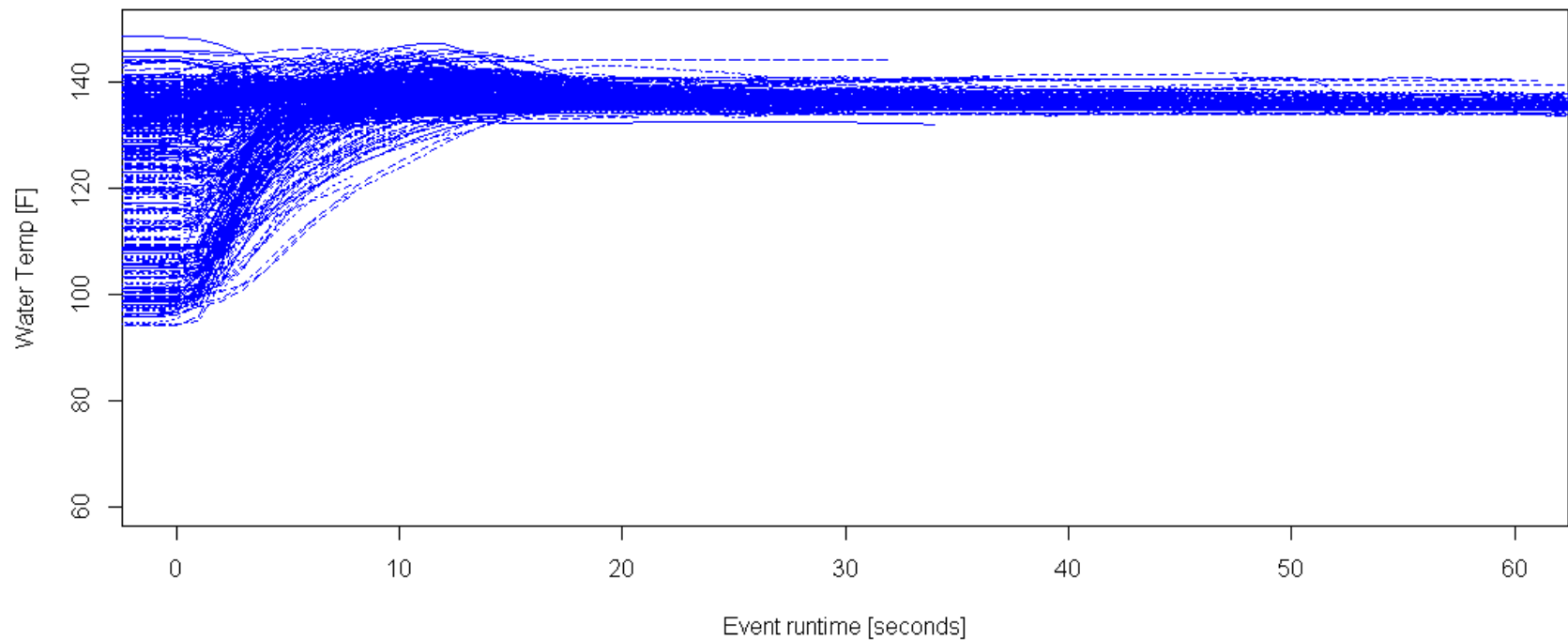

# Efficiency

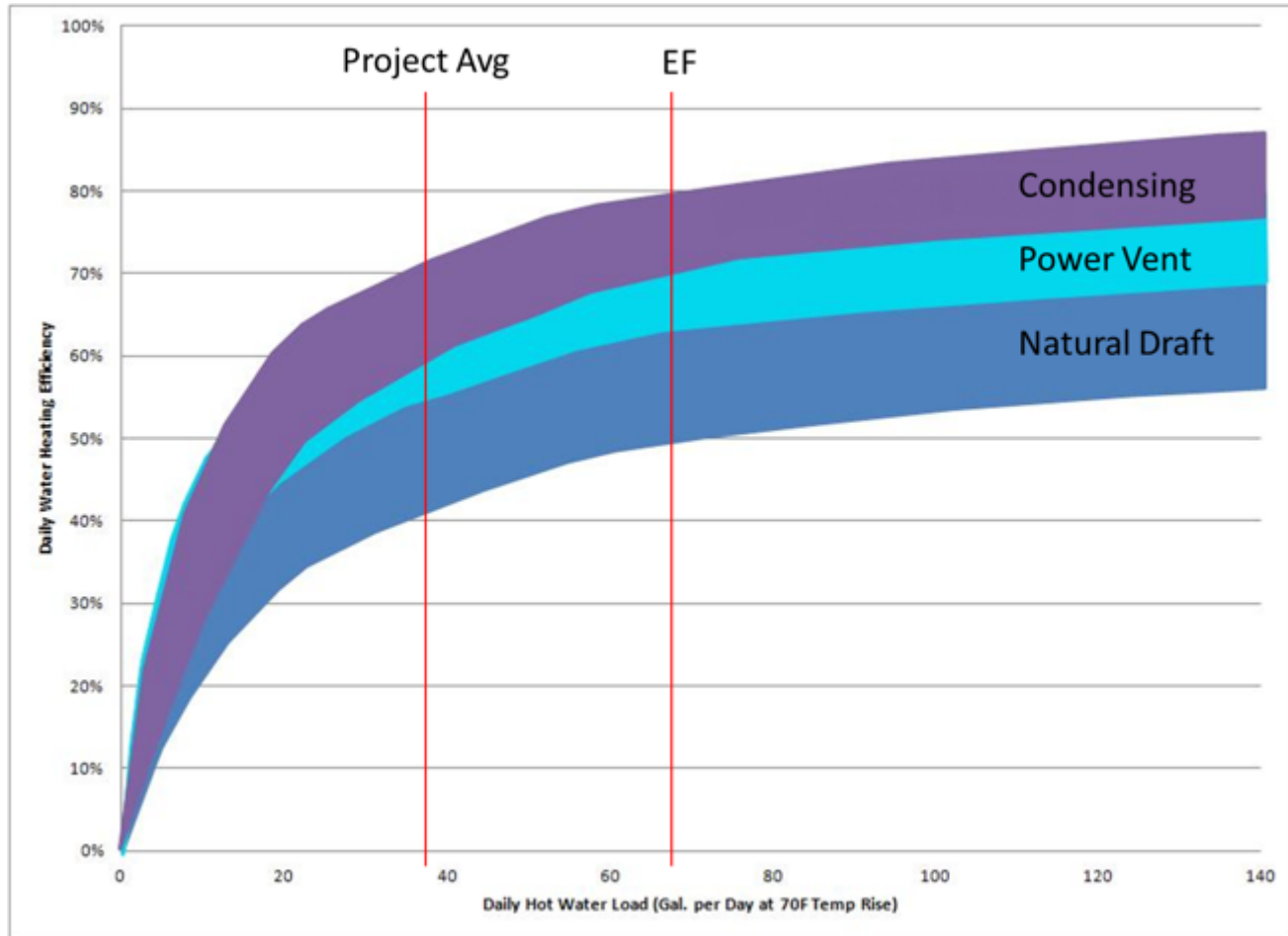

# Improving Efficiency

## Reducing stand-by loses with an insulation blanket

Temperature Setpoint (F)	Annual Savings		Payback (years)
	(therms)	(%)	
120	5.5	3%	4.8
130	11.4	6%	2.3
140	14.6	7%	1.8

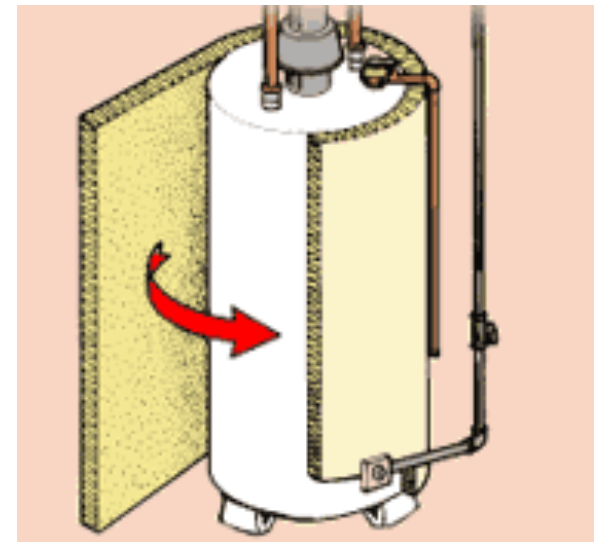

Assumes \$20 cost and \$0.75/therm

# Improving Efficiency

## Reducing stand-by loses by reducing temperature

Tset	Savings	
Setback °F	therm/dy	therm/yr
5	0.02	7.3
10	0.04	14.6
15	0.06	21.9
20	0.08	29.2
25	0.1	36.5

- Set Temperature Impacts
  - Delivered water temperature
  - Risk of scalding
  - Risk of legionella

# Gas Tankless Water Heaters

- Types
  - Condensing
  - Non-condensing
- Operation
  - No storage, water is heated as needed
  - Eliminate stand-by loses
  - 80%-95% EF

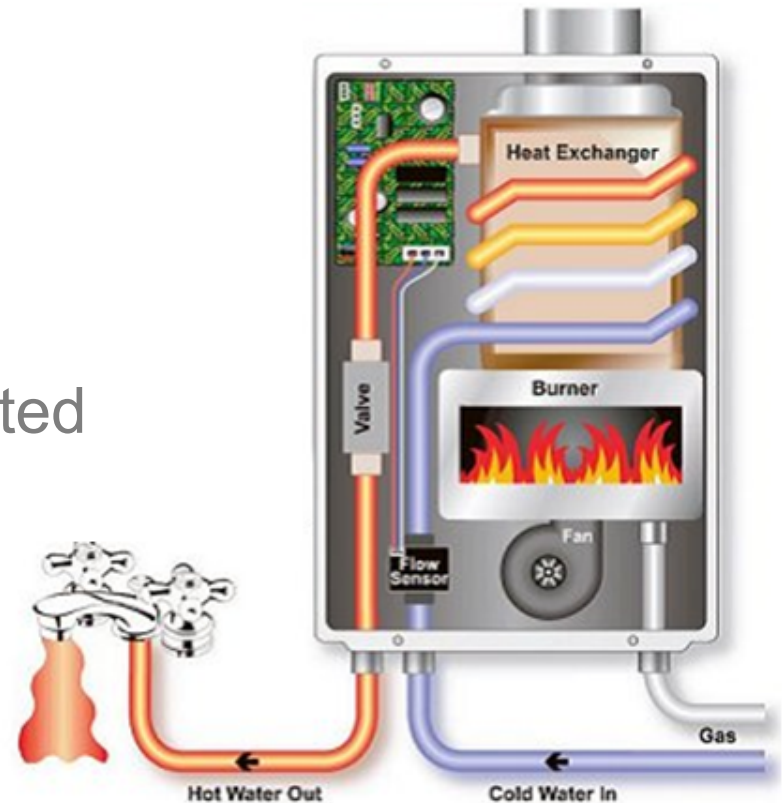



# Issues Facing Tankless Water Heaters

- Hot water quality
  - Delayed delivery time
  - Cold water sandwich
  - Consistent Supply temperature
  - Minimum flow rate for firing
  - Performance for multiple simultaneous uses
- Higher installation costs
- Maintenance costs



# Temperature Profiles

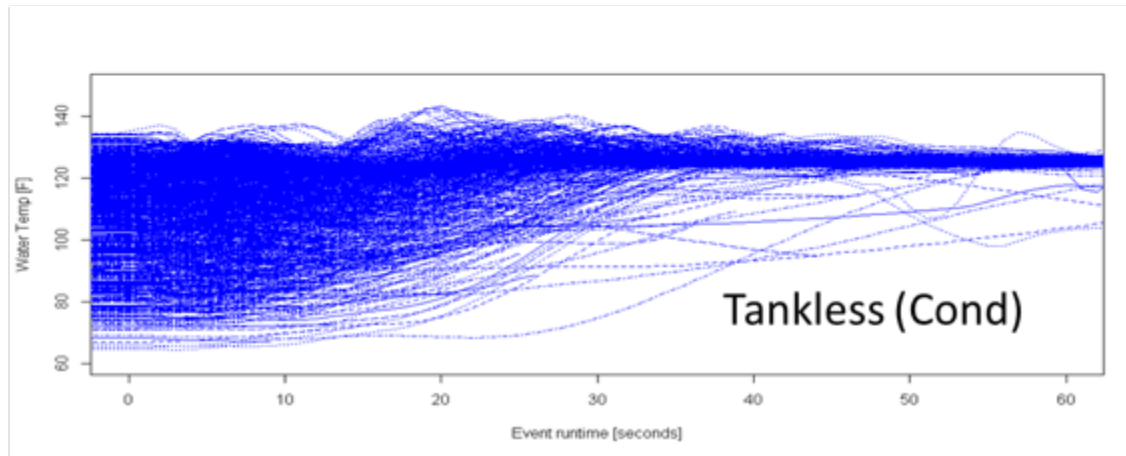
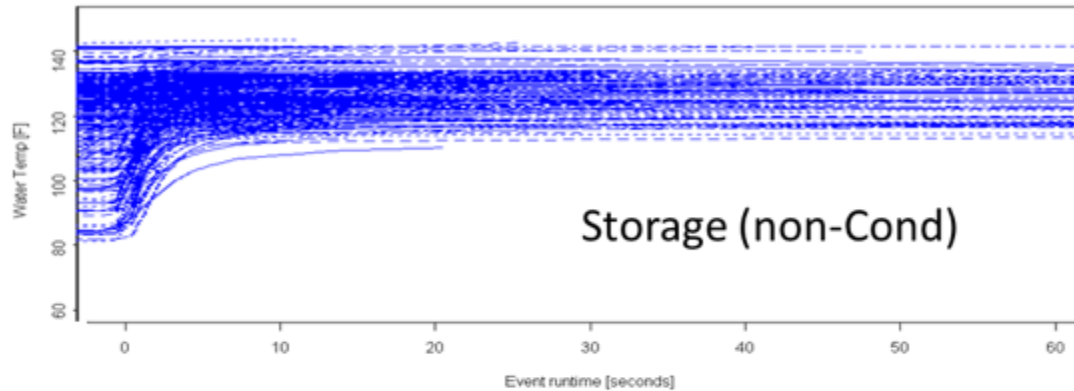

# Cold Water Sandwich

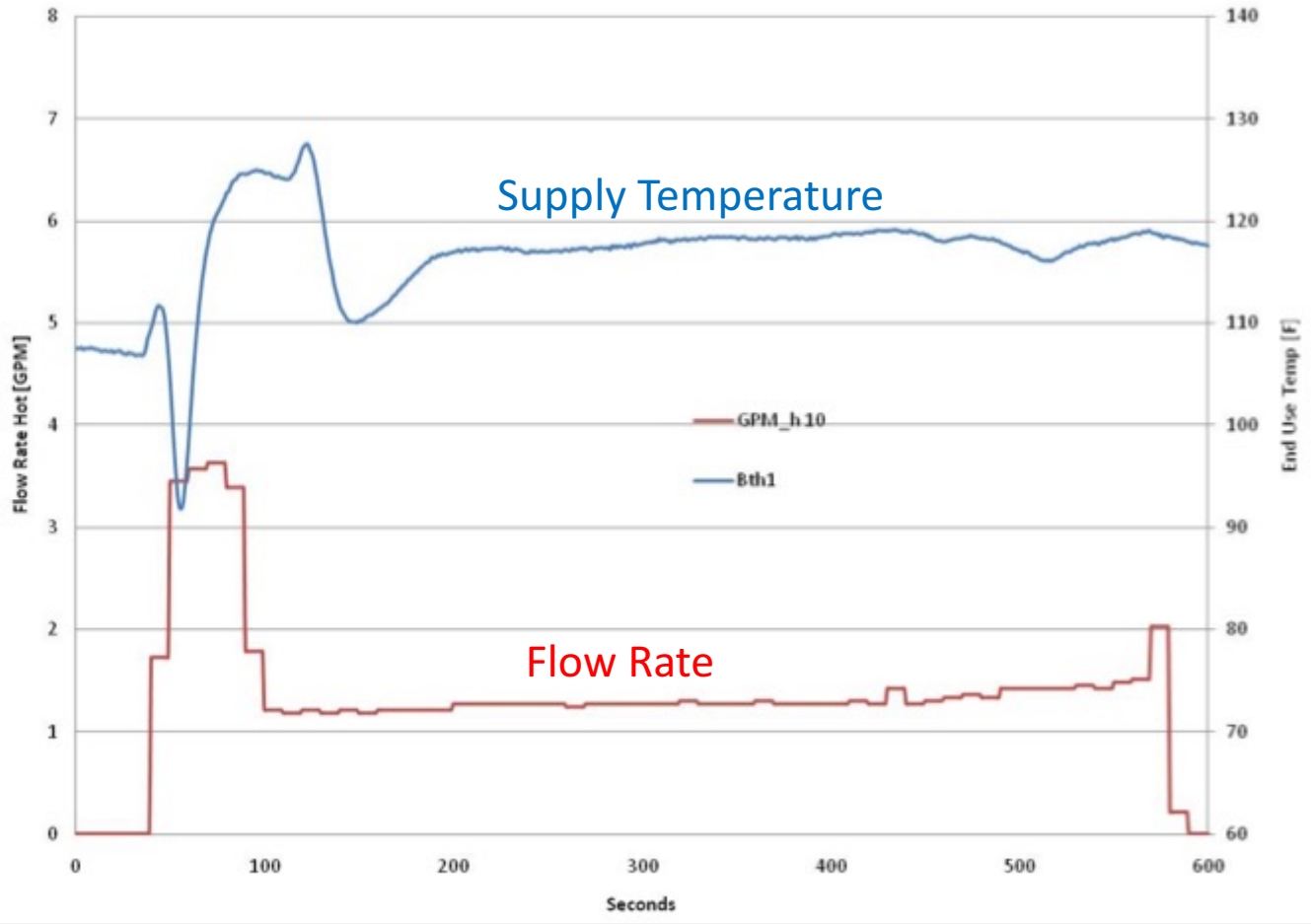

# Home Owner Survey – continuous supply of hot water without running out

	Storage Heater			Tankless Heater		
	Unfavorable	No Effect	Favorable	Unfavorable	No Effect	Favorable
Delay Time Until Hot Water Arrives	22%	11%	67%	72%	17%	11%
Not Running Out of Hot Water	56%	11%	33%	6%	11%	83%

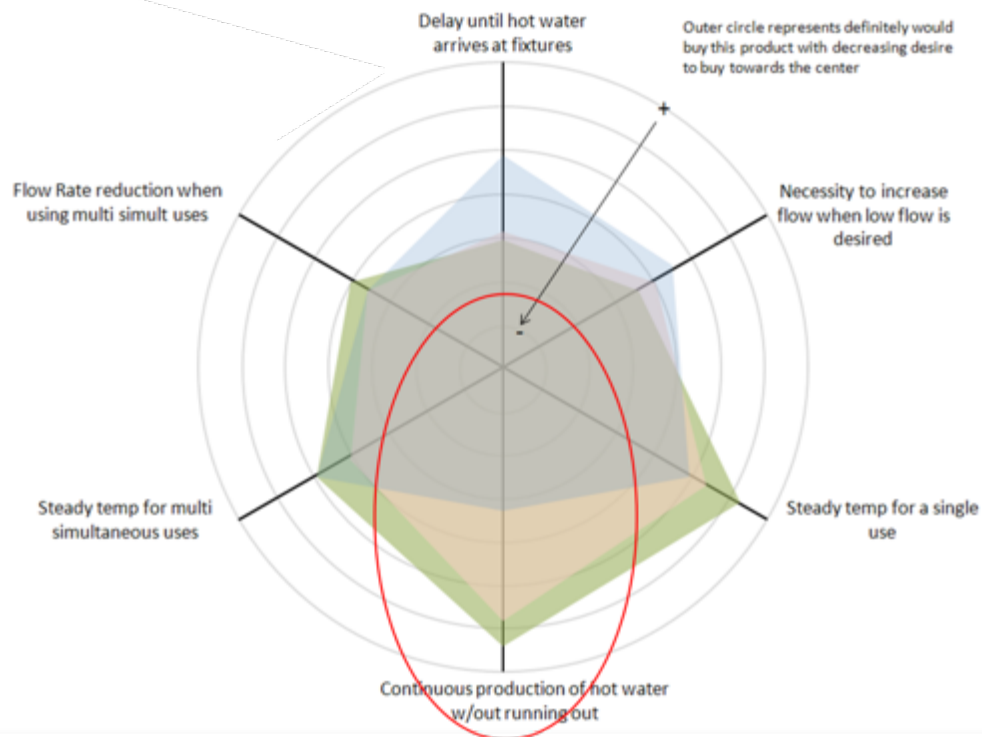

# Gas Hybrid Water Heaters

- Types
  - Small tank (0.5 to 2 gallon) and big burner (up to 199,000 Btu/hr)
  - Medium tank (around 20 gallon) and medium burner (100,000 Btu/hr)
- EF 85% to 95%
- Balances benefits and drawbacks of tanks and tankless
  - Water delivery
  - Stand-by Losses



# Water Delivery Temperature

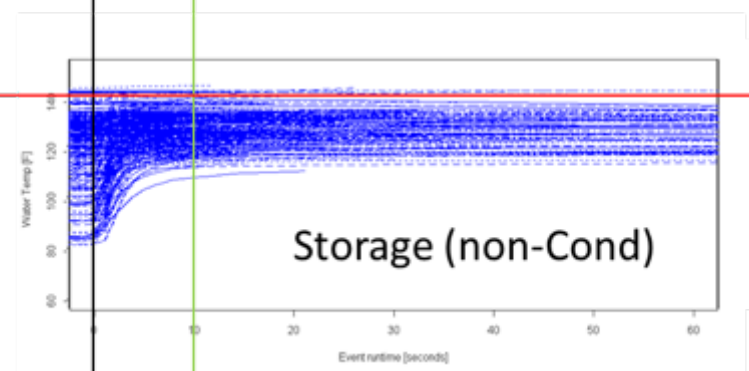
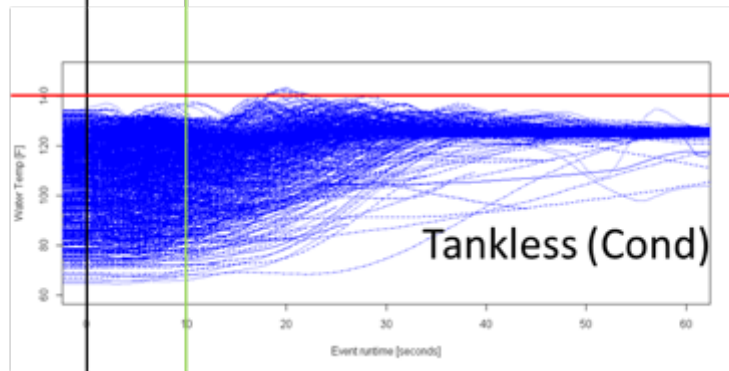
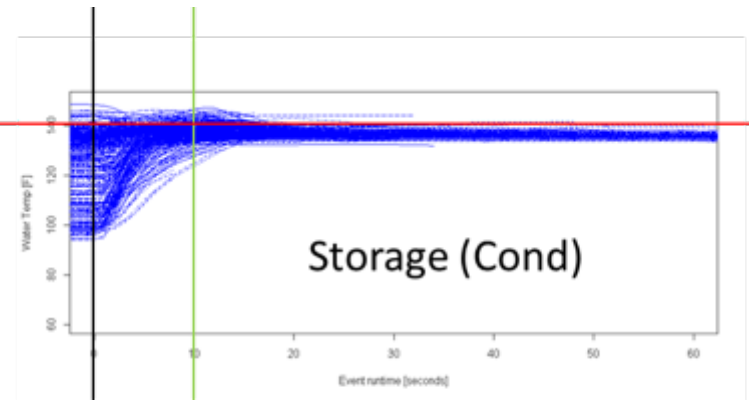
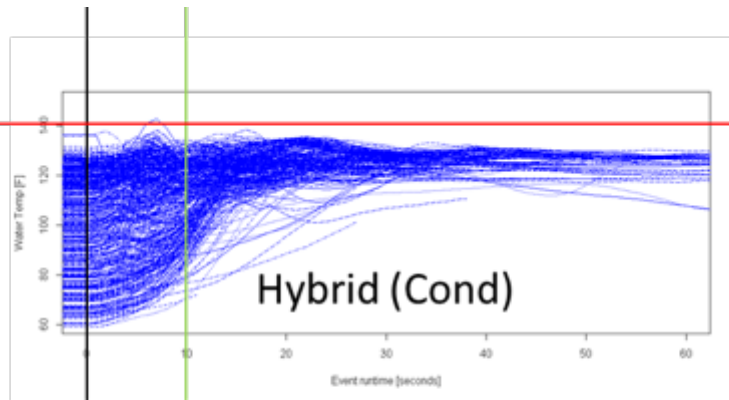

# Stand-by Loses

- Vary dramatically from unit to unit
  - Storage volumes
  - Controls
  - Insulation levels
  - Vent loses

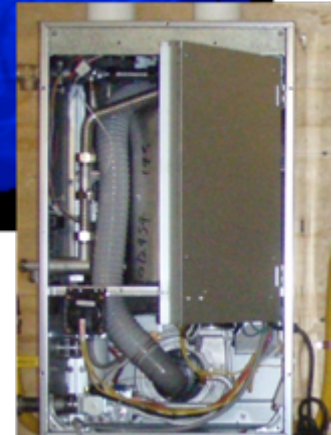
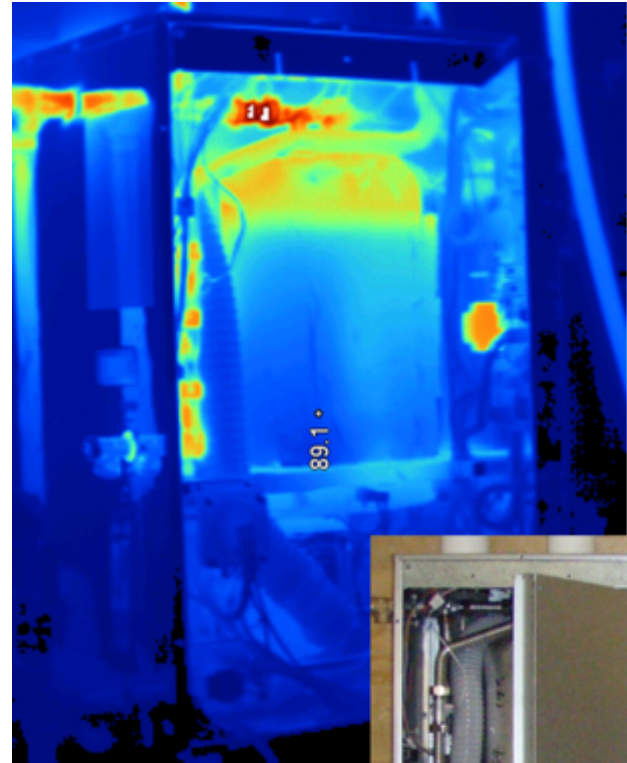



# Gas Water Heater Comparison

- Efficiency
- Installation
- Safety
- Economics

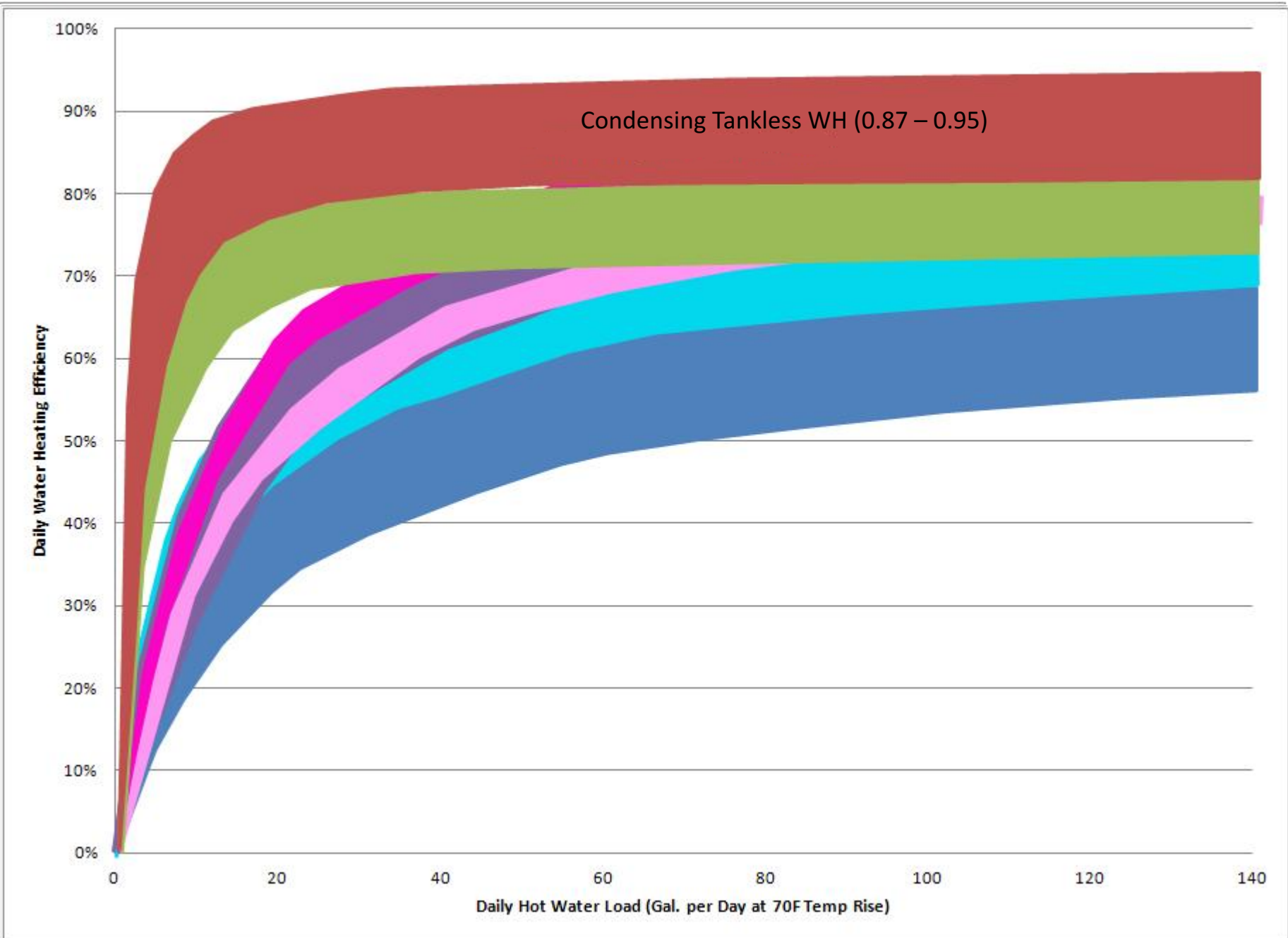



# Tankless Efficiency by Draw Length

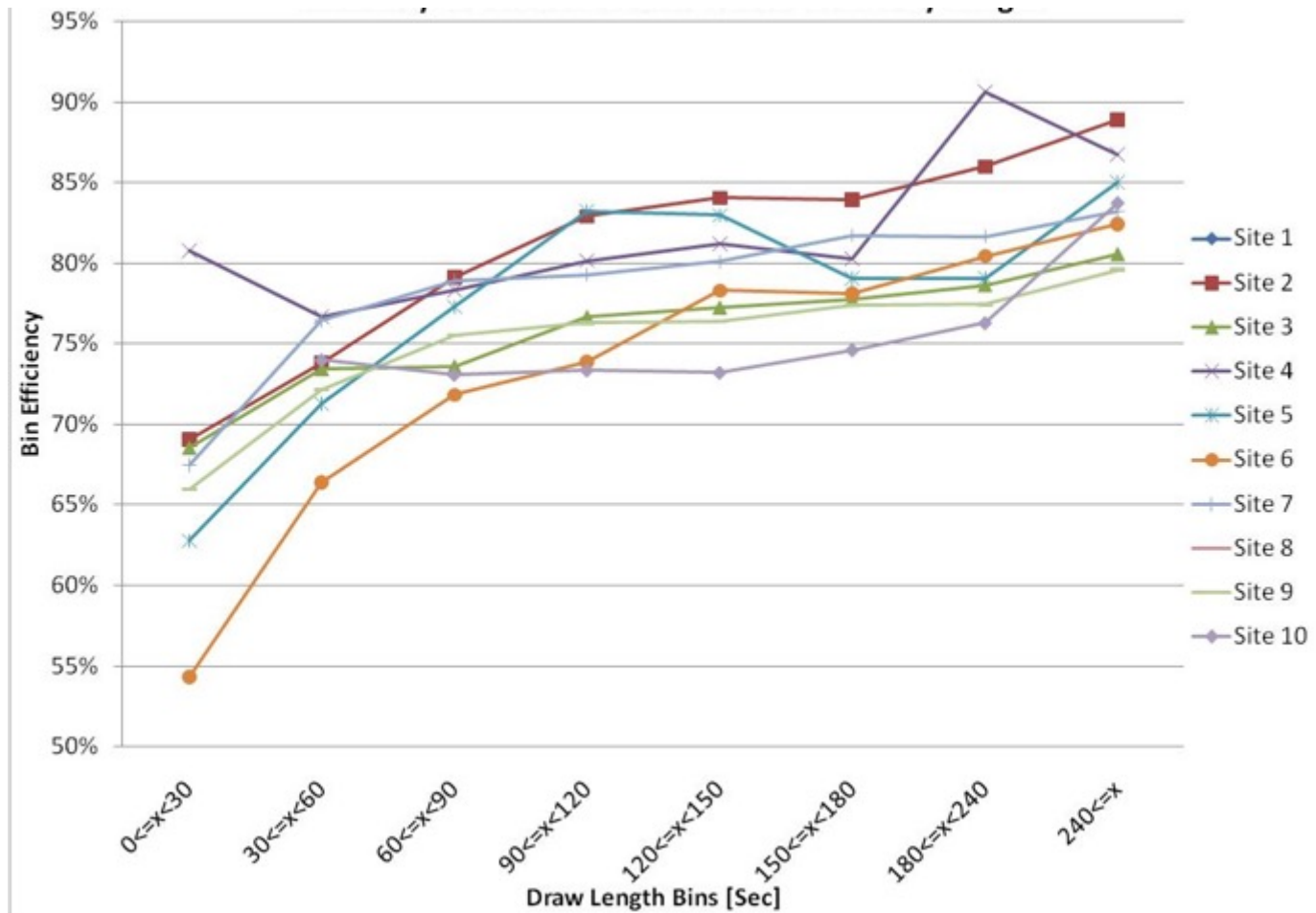

# Impact of Stand-by Loss

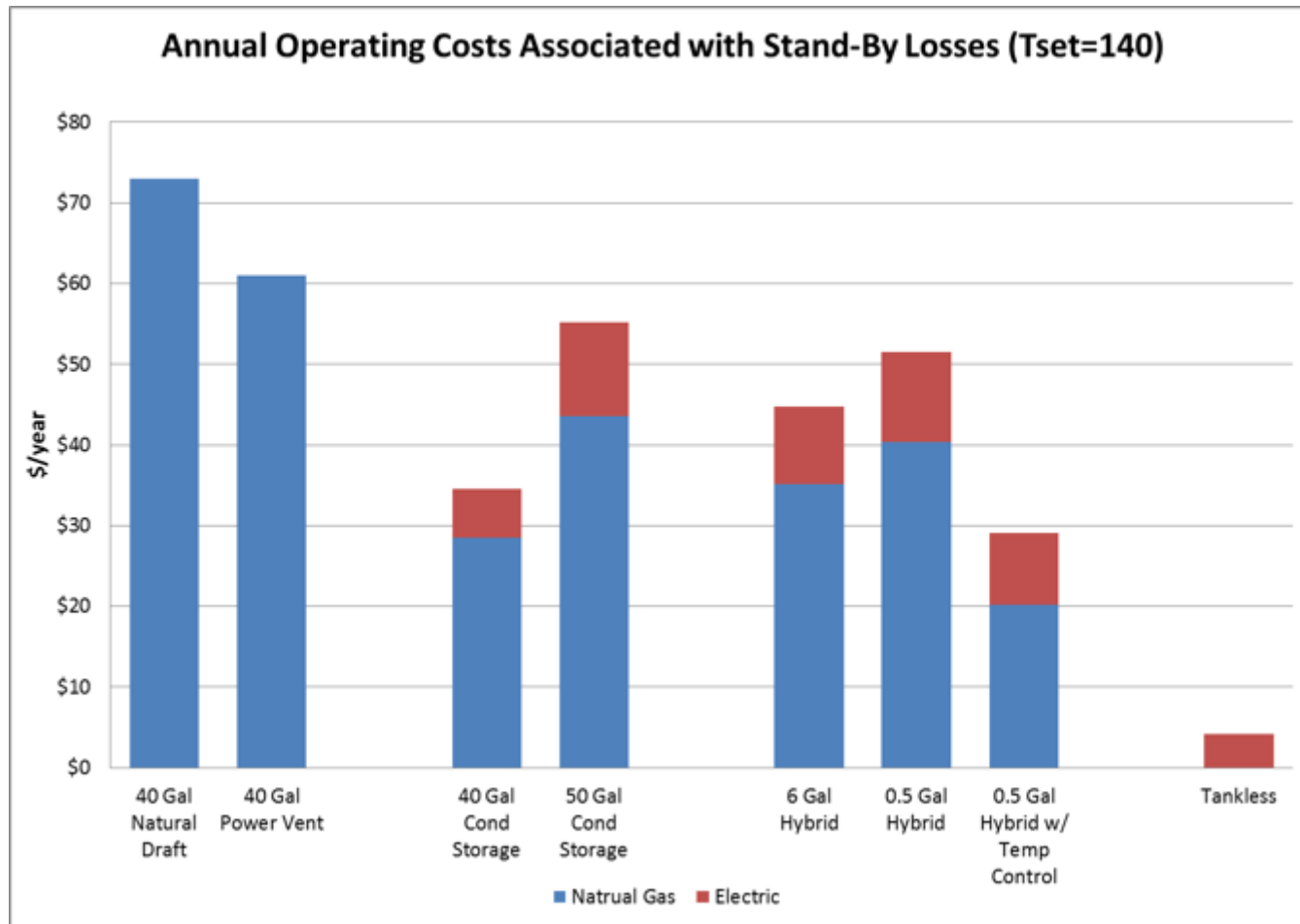

# Impact of Stand-by on Efficiency

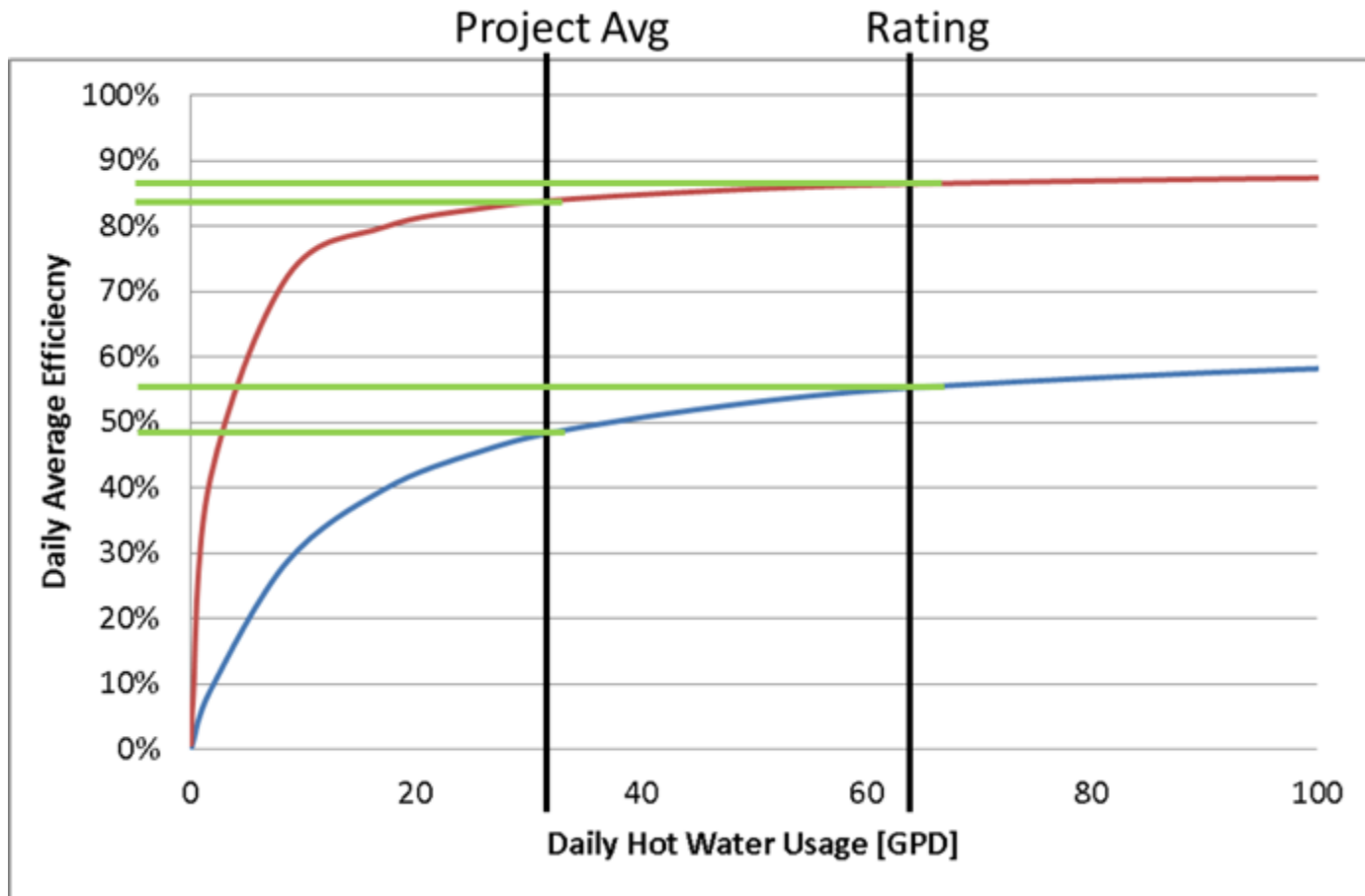

# Installation: Venting



# Installation: Venting

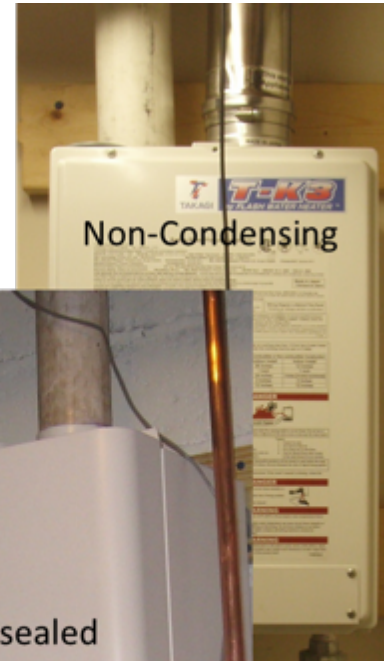
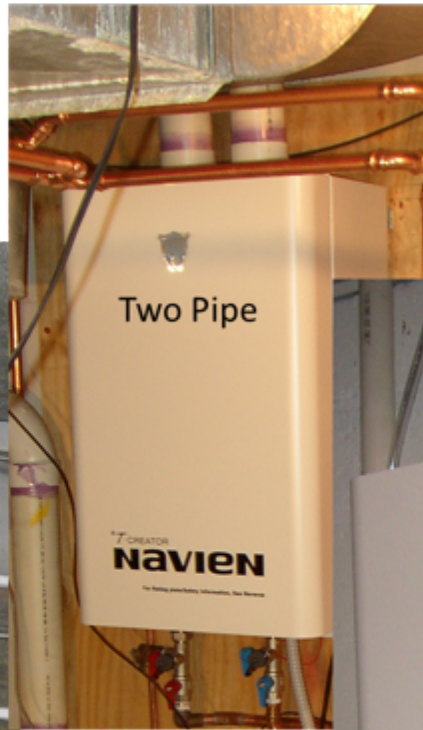



# Larger Burners = Gas Line Upgrades

- Water heaters with burners greater than 100,000 Btu/hr
  - Most tankless
  - Some condensing storage
  - Some hybrid
- Occasionally require a meter upgrade (more common in older homes and/or homes with lots of gas uses)
  - 0 of 25 in our studies
- Sites commonly required a increased size gas line from the water heater to the gas meter
  - 14 of 25 in our studies

# Installation: Other Additions

## Condensate Drainage



## Electrical





# Safety

- Combustion safety
  - Lower efficiency natural draft units can have issues
  - Power vented and sealed combustion units are safer
- Scalding
  - All water heaters

<b>Water Temperature Setting</b>	<b>Exposure Time</b>
Water at 120 degF	5 minutes
Water at 130 degF	30 seconds
Water at 140 degF	5 seconds
Water at 150 degF	1.5 seconds
Water at 160 degF	.5 second



# Savings

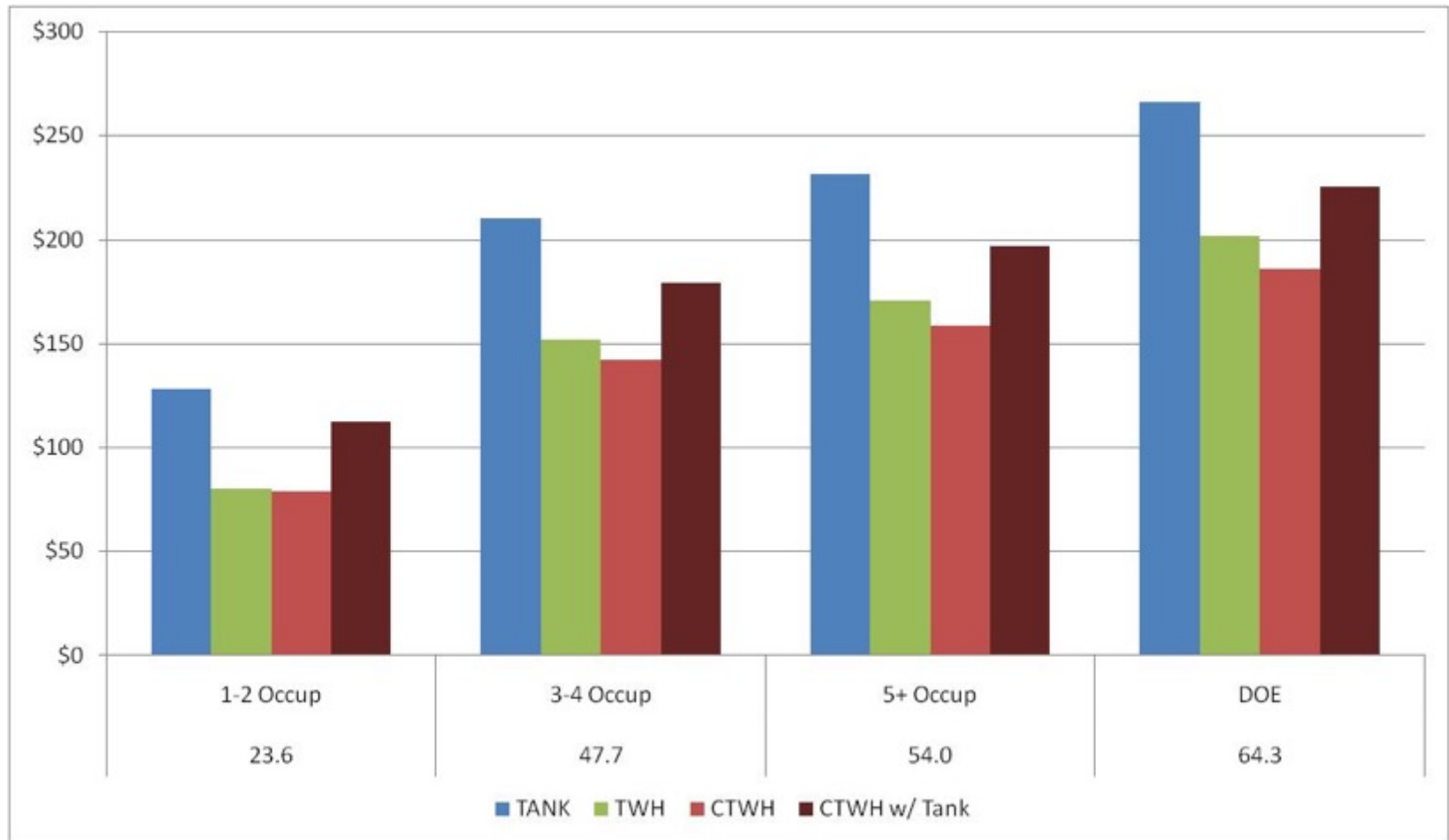

# Paybacks

<b>Paybacks for Non-Condensing Tankless Water Heater</b>			
	<b>Incremental Cost</b>		
<b>Load</b>	<b>\$500</b>	<b>\$750</b>	<b>\$1,000</b>
Small (24 GPD)	10	16	21
Medium (48 GPD)	9	13	17
Large (64 GPD)	7	10	13
Very Large (90 GPD)	6	9	12



<b>Paybacks for Condensing Tankless Water Heater</b>			
	<b>Incremental Cost</b>		
<b>Load</b>	<b>\$500</b>	<b>\$750</b>	<b>\$1,000</b>
Small (24 GPD)	10	15	20
Medium (48 GPD)	7	11	15
Large (64 GPD)	5	8	11
Very Large (90 GPD)	5	7	9

# Gas Heat Pump Water Heaters

- Several technology options in development
- Absorption Heat Pump Water Heater
  - Nearing market introduction
  - Estimate UEF ~1.3
  - SMTI and GTI have completed several field demonstrations



# Electrical Water Heating





# Electric Storage

- Water stored at temperature
- When tank temp drops below certain point elements turn on
- Rated EF from 0.89 to 0.95
  - Insulation levels main difference
- Typical input: 4 to 6 kW
- Typically 40 to 60 gallons of storage
- No burner venting results in lower storage losses than similar gas units
- Hot water delivery similar to gas storage WHs

# Min Eff Storage: Gas vs Electric

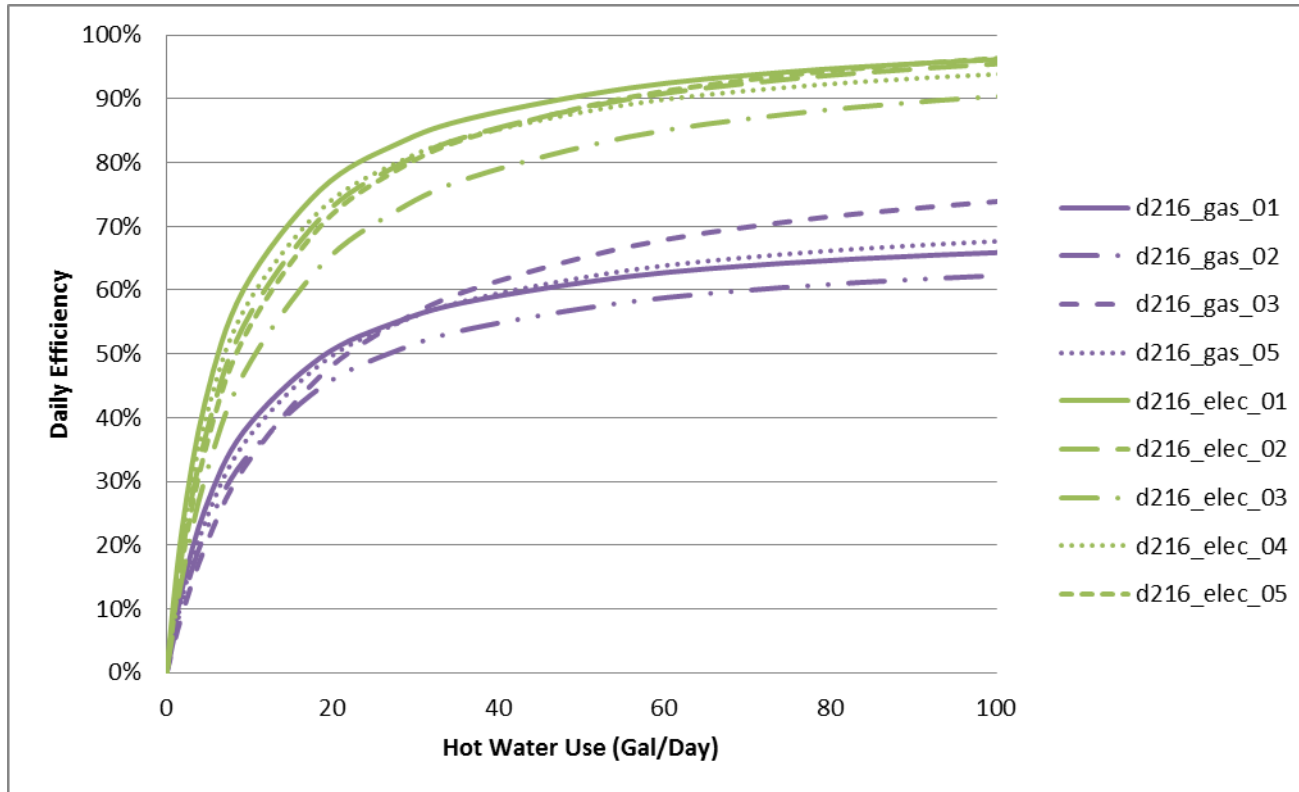

# Heat Pump Water Heaters

- Integrated heat pump and storage
- 50 to 80 gallons
- COP ~ 2 to 2.5
- Optional ducted venting
- Cooling capacity of 15 to 30 kBtu/hr (~1.2 to 2 tons)
- Multiple modes of operation
  - Heat pump only
  - Hybrid
  - Resistance only

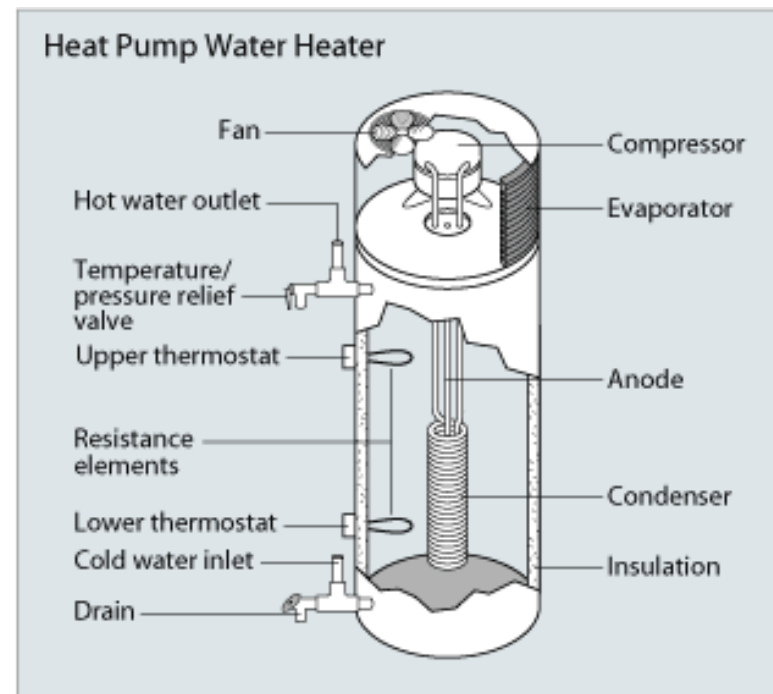

# How HPWHs work

Diagram 1

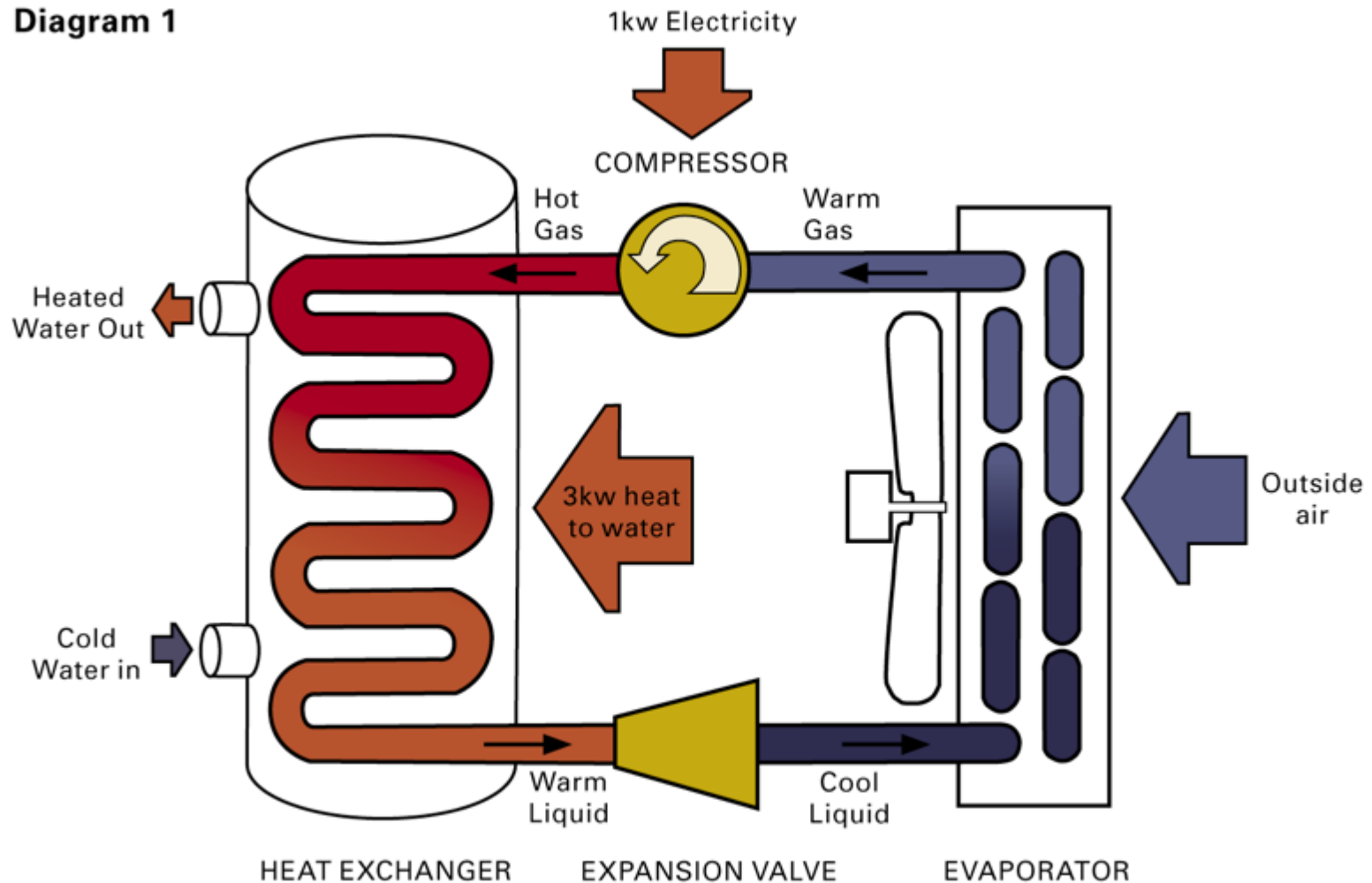



# Heap Pump Water Heater Performance

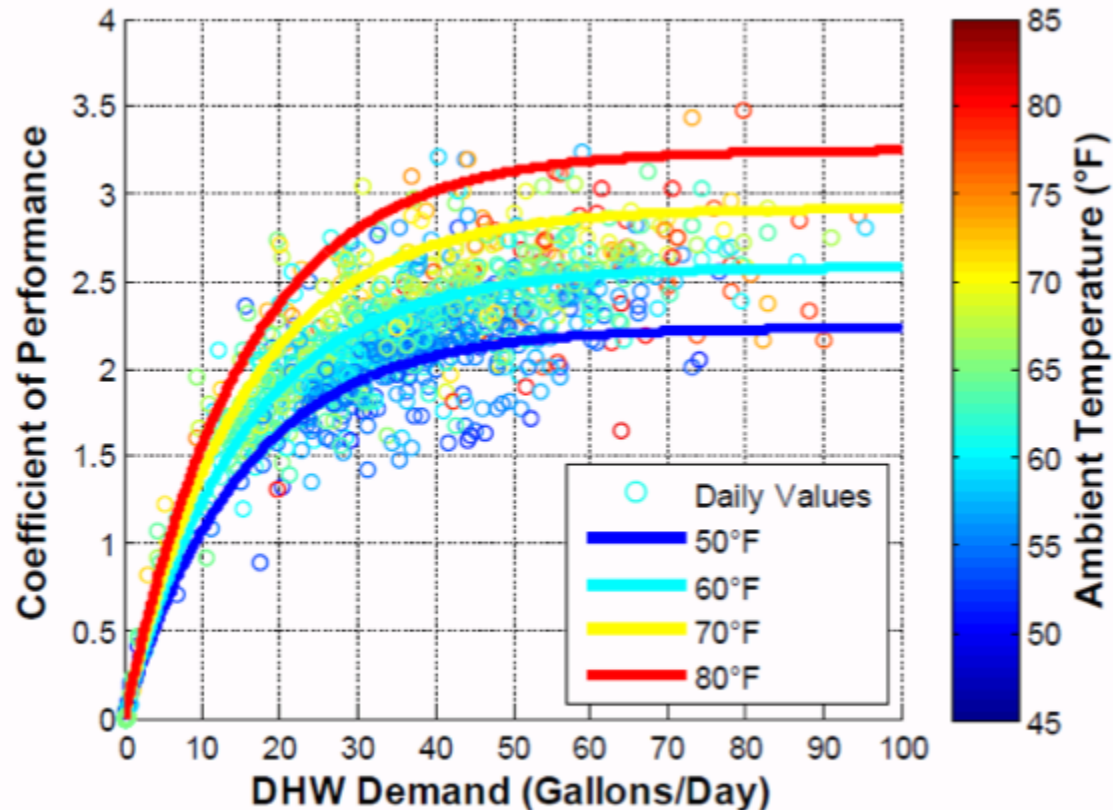

Figure 5. Efficiency of a 50-gal HPWH operating in heat pump mode



# HPWH Space Conditioning Impact

- Lots of modeling around the country still need DATA!!
- Lots of variables:
  - Installation location
    - In conditioned space – Max effect
    - In garage – No effect
    - In semi-conditioned (basement/craw space) – secondary effect
  - Conditioning load of house and heating equipment
    - Efficiency, set points, use, etc
- Limited lab data shows HPWHs deliver ~1 ton of cooling at 50 gallons per day



# CEE HPWH Savings Calculator

- Inputs:
  - Geographic location
  - Space heating fuel & system type
  - Air conditioner type and typical operation
  - Number occupants
  
- Installation location
  - In conditioned space – Max effect
  - In garage – No effect
  - In semi-conditioned (basement/craw space) – secondary effect
- <http://www.mncee.org/Innovation-Exchange/Resource-Center/Data-and-Reference/Heat-Pump-Water-Heater-Calculator/>

# CEE HPWH Savings Calculator

Heat Pump Water Heater Savings

Water Heater	Installed COP	Hot Water Usage (GPD)	Hot Water Energy Usage (kWh/year)	Cooling Benefit (kWh/year)	Heating Increase (kWh/year)	Annual Operating Cost (\$/year)	Annual Savings (\$/year)	Simple Payback (Years)
Electric Resistance, Baseline	0.89	54	3,770	0	0	452	-	-
Heat Pump Water Heater	1.64	54	2,043	16	362	287	165	6.1

The table above shows the estimated performance of a heat pump water heater in your home. The information you provided was used to estimate the hot water usage both in volume and energy used in your home. This usage information was used to determine the performance and savings expected from the heat pump water heater as well as the impact of the heat pump on the space conditioning use of the home (Cooling Benefit and Heating Increase). The water and energy usage patterns for a sample day are shown below. The graph shows what the electricity use pattern would be for either a heat pump water heater or an electric resistance water heater under the same hot water use.

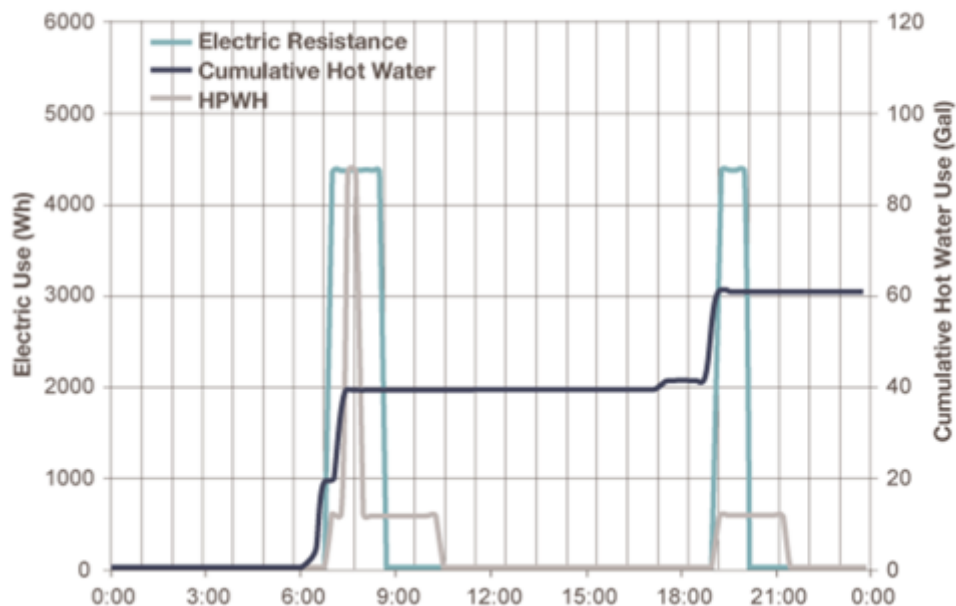



# Electric Thermal Storage

- Increases the temperature WH at low electricity use periods (overnight)
- Not an energy savings measure, but reduces peak load
- Units typically have larger storage capacity's, 60 gallons plus
- Some units have increased insulation to prevent increasing stand by loses

# • • • Grid-Interactive Water Heater

- Two-way communications
  - Rapid response to grid
  - Turns water heaters into quick responding battery
- 
- Lots of Benefits
    - Load shaping
    - Demand response
    - Grid stabilization
    - **Renewable integration**





## Electric tankless

- Major market as point of use heaters
  - 3.5 kW on regular electric service – 1 sink
  - 5 kW on 240 volt – 1 bathroom
  - Reduce distribution losses compared to central system
- Whole house units available for small homes
  - Require larger electric hook ups
- Rated EF of 0.90 to 0.95



## Distribution efficiency

- 5% to 27% of hot water is from draws where fixture is never gets hot (by volume)
- Draws lost 2-8 °F, 3% to 12% loss
- Depending on usage patterns, hot water left in pipes can reduce total system efficiencies to less than 25%
  - If draws are well grouped these losses are very small
- Point of use heaters can reduce these losses to almost zero



# COP for electric water heaters

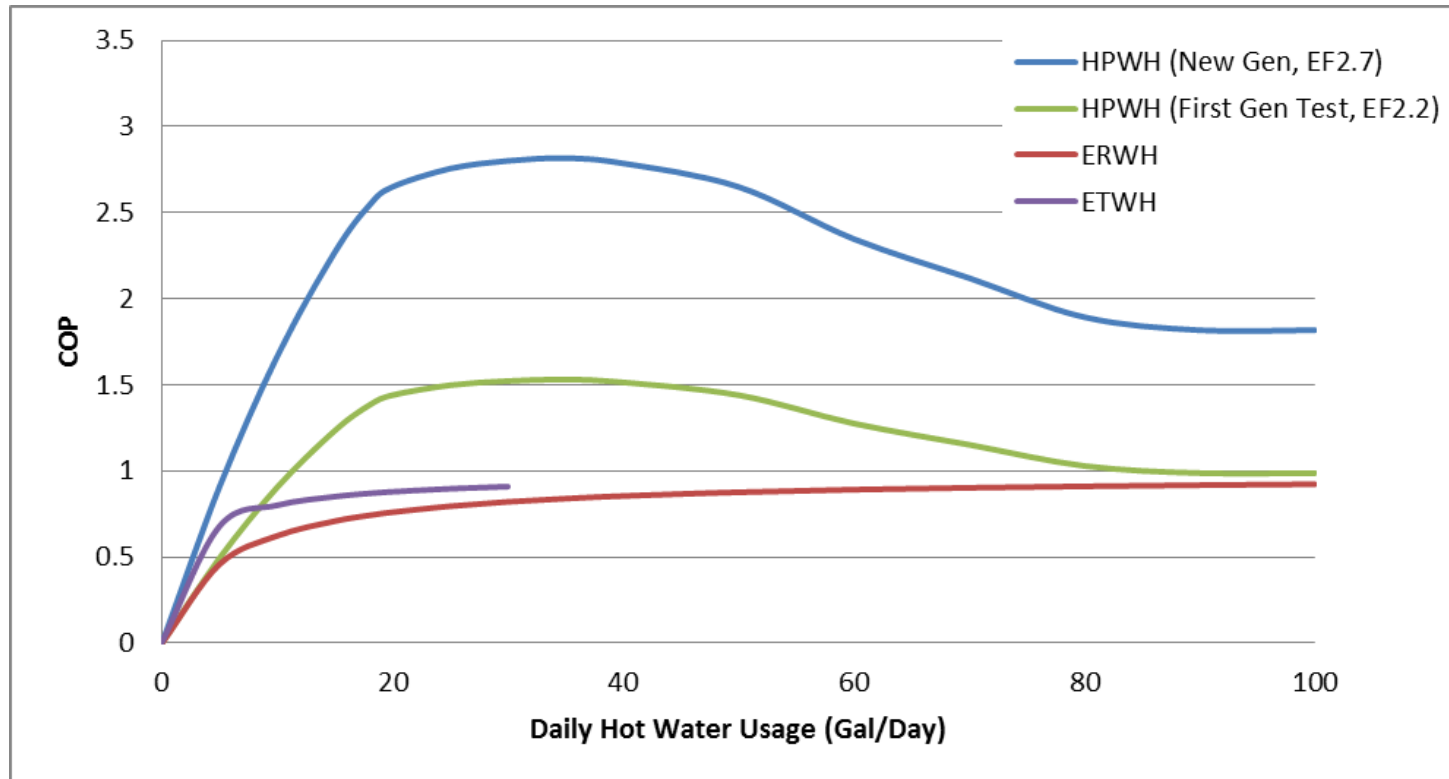

# HPWH & Electric Loads

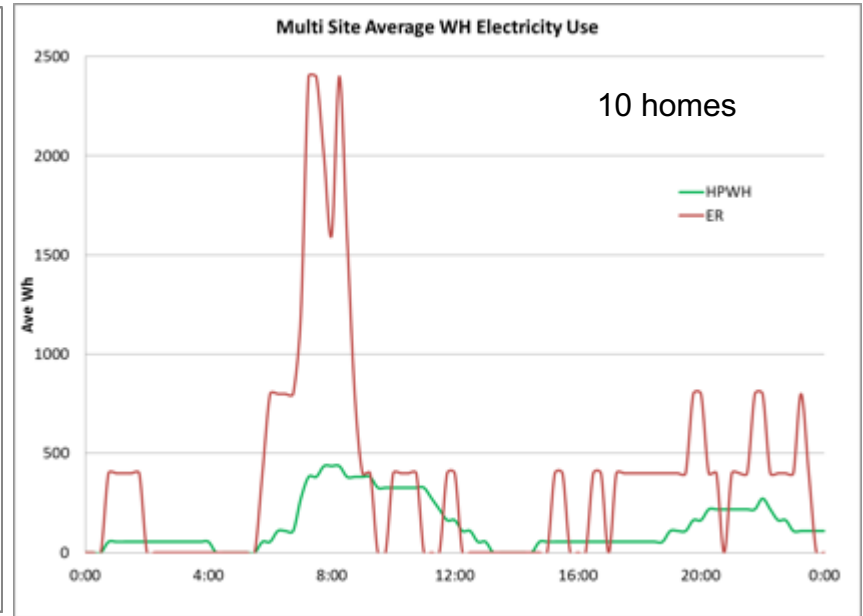
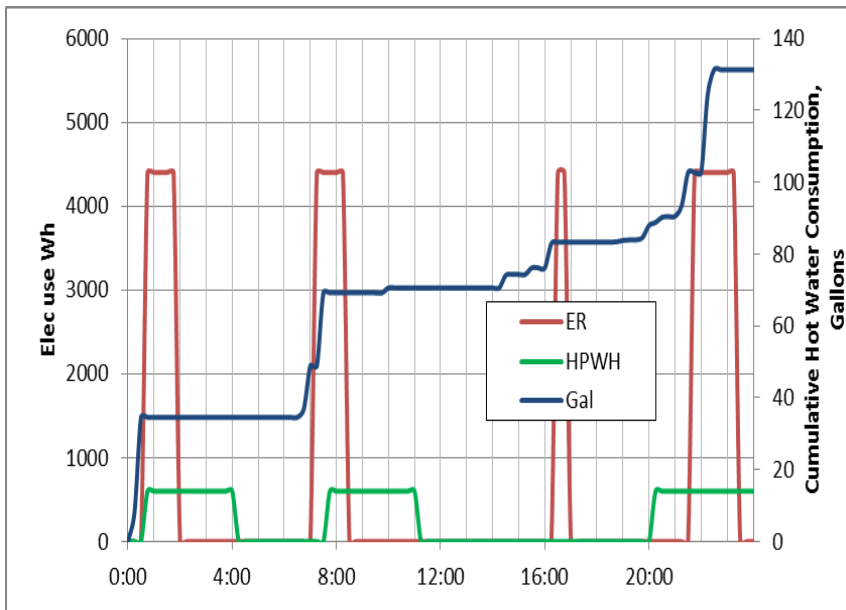

# Distribution





# Distribution Options

- New Construction
  - System Type
    - Focus on low volume and quick delivery
  - Retrofit
    - Most opportunities are in controls
- PLUG for New construction:
  - Gary Klein
  - <http://www.garykleinassociates.com/>
  - “It’s Not Just the Water Heater Anymore”

# Beyond Water Heater for Retrofitting Homes



# Smart Water Heater Controls



# Installation and Validation

- Tank Sensor through TMP Valve



- Control Units

- Electric
- Gas Valve



- Additional Sensors

- Leak Detection
- Water Inlet Temperature



# Supply Water Temperature

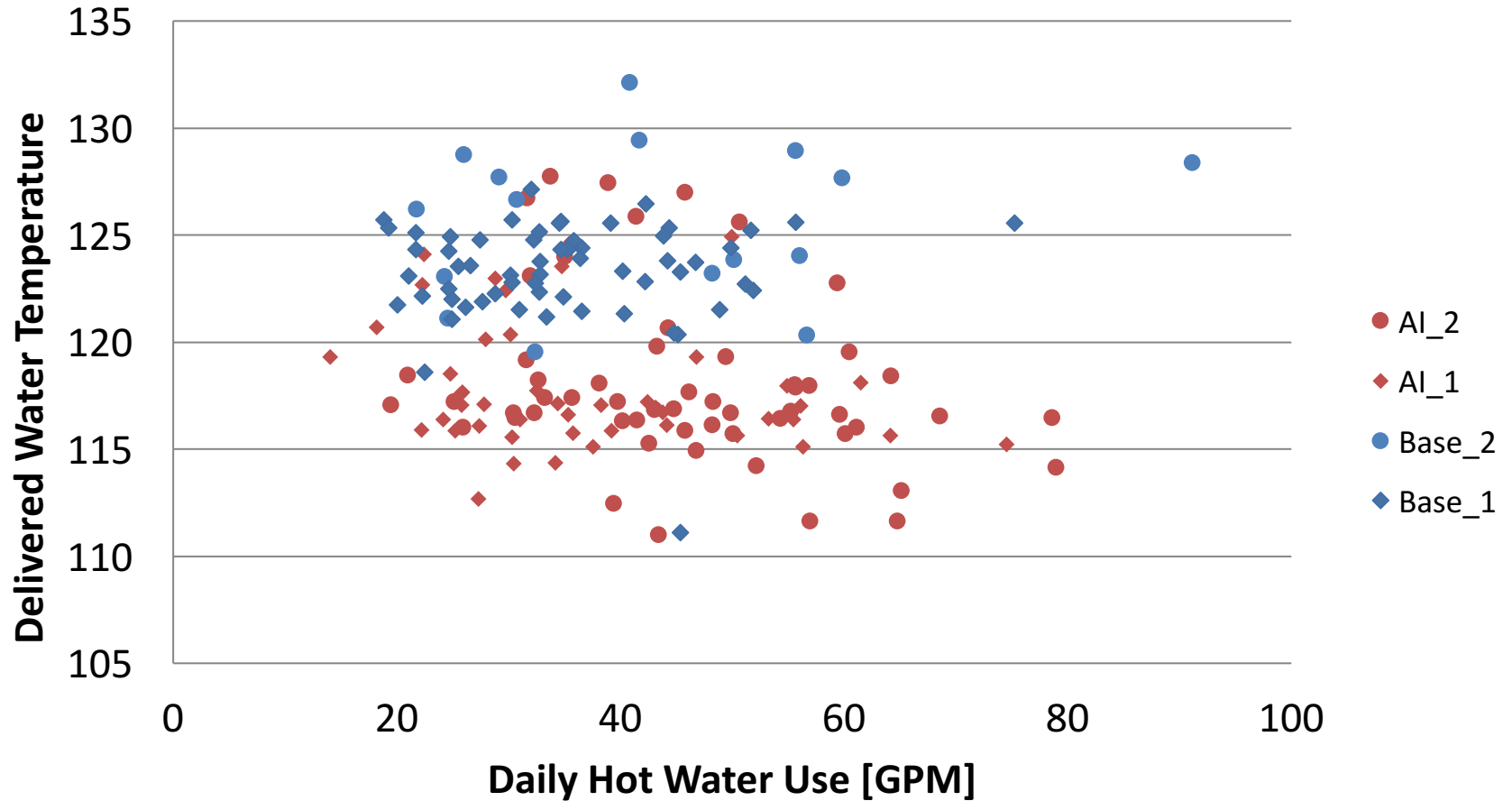



# Energy Use per Gallon of Hot Water

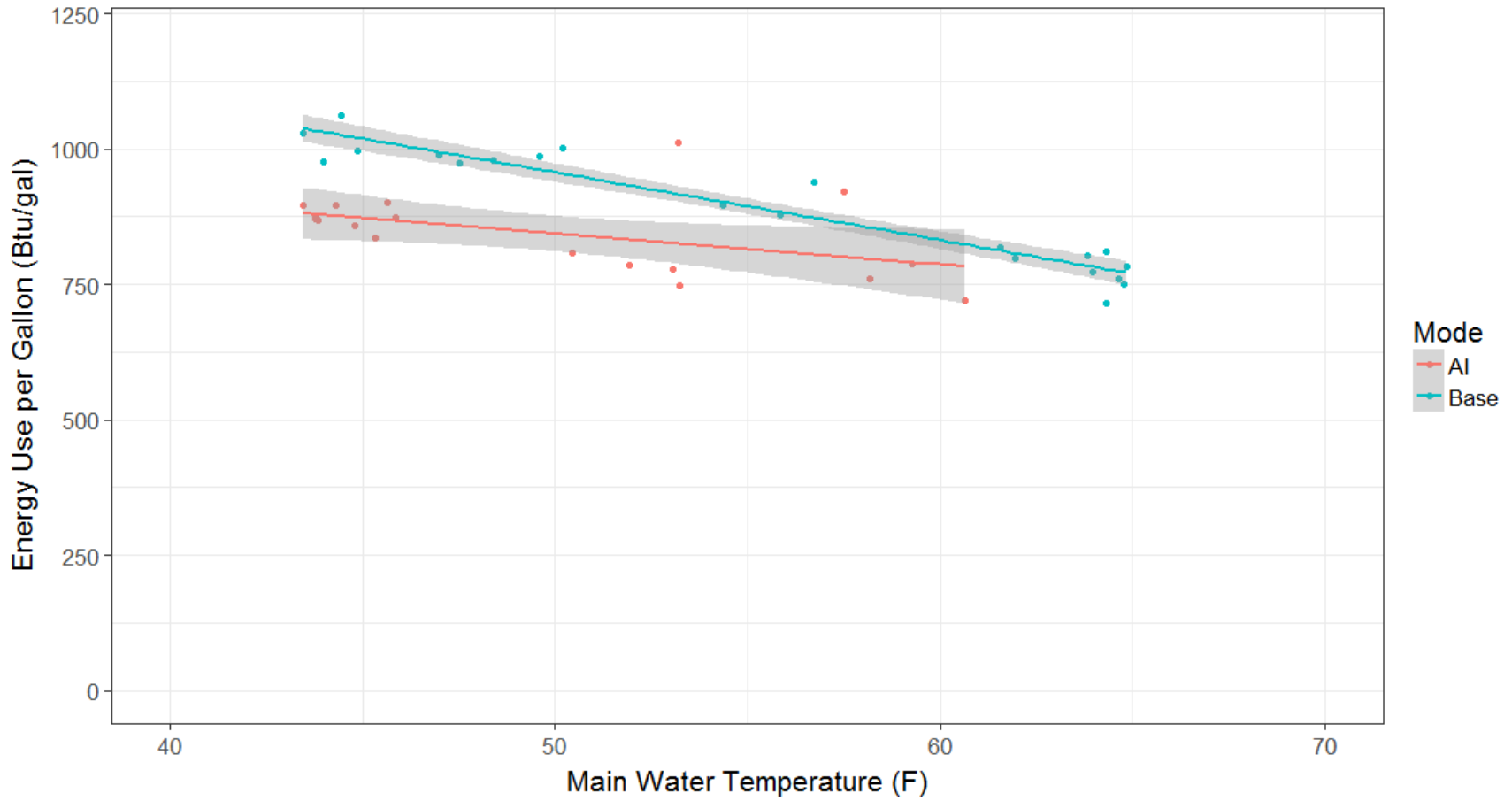

# Energy Use Profile

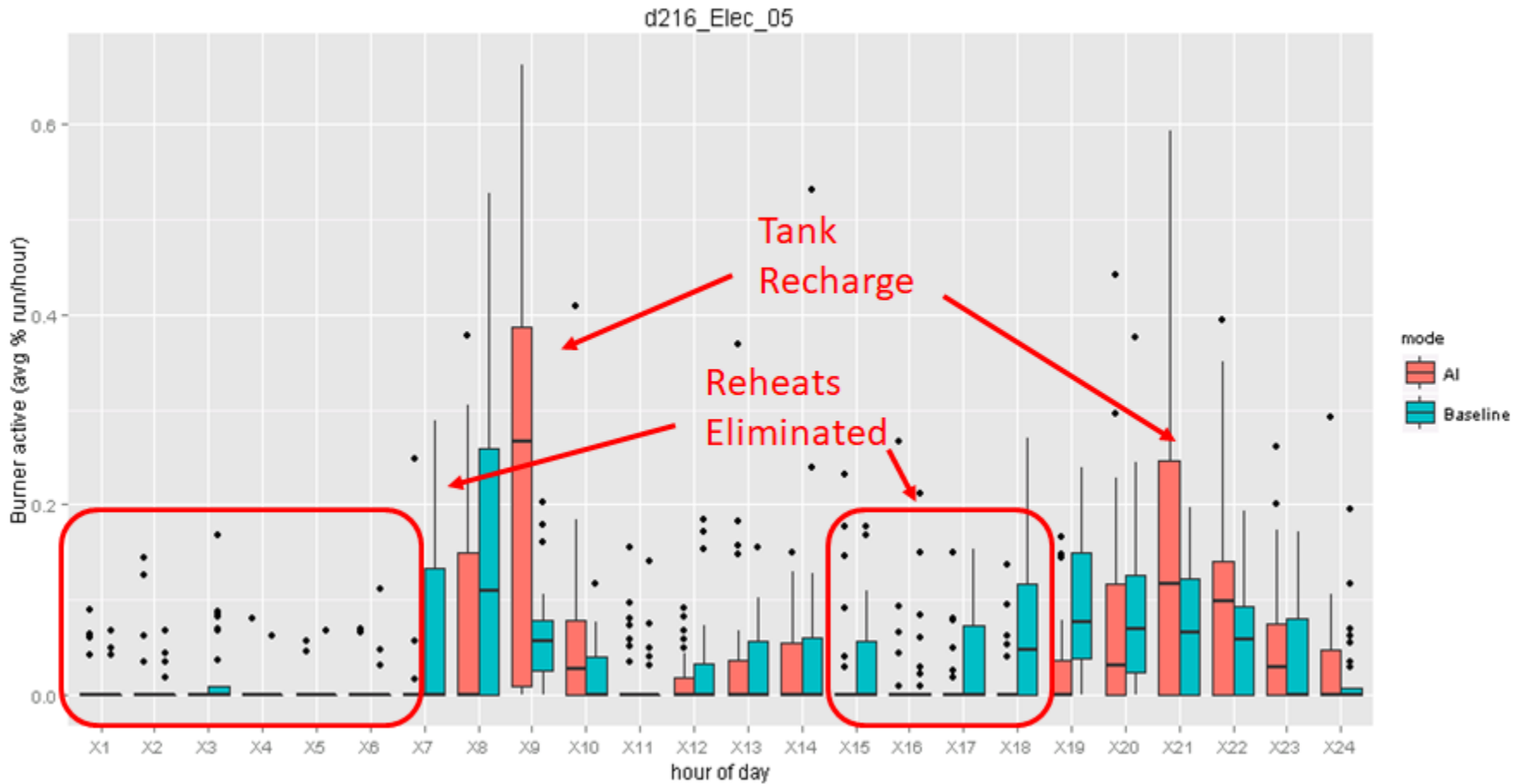

# • On Demand or Recirculation Control

- Controlled Recirculation
- Several options
  - Flow activated
  - Button activated
  - Motion sensor activated
- Hot water quick
- Reduced recirc pump times
- Reduced thermal losses



# Multi-fam, Hotels, and Commercial

- CEE recently conducted a research project on Demand Control Recirculation
  - Controls a recirculation pump that is typically on 24/7
- 12% to 18% thermal savings
- 82% to 96% electric pump savings

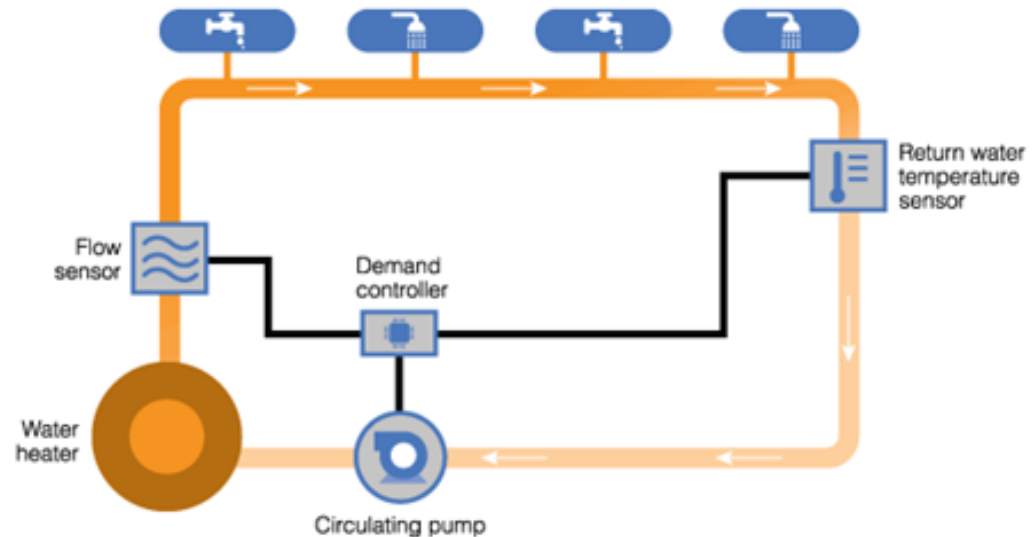



# Conclusions

- Smart controllers can
  - control water heater usage profiles
  - eliminate unnecessary reheats
  - reduce energy use for water heating
  - Measure, calculate and provide data and information to occupants

## Final Reporting

- Full report due Summer 2018
- Webinar: Available for download at [mncee.org](http://mncee.org) and DOC websites

# What to look for in the future





# New Products

- Further developments with
  - thermal storage HPWH
  - Gas fired heat pump technology
  - ETS for renewable integration and demand control
  - Improved “smart” functionality
- New construction
  - Changing codes and rating (HERS) systems to allow and credit better plumbing design

THANK  
*you!*









# Potential Plumbing Code Changes

- Allowing smaller pipe diameter
  - Requiring low water volume between WH and fixtures
  - Pipe insulation guideline/requirements
  - Recirculation controls
- 
- International Energy Conservation Code (IECC-R and IECC-C)
  - International Association of Plumbing and Mechanical Officials (IAPMO) Uniform Plumbing Code (UPC)

# Impact on Inlet Water Temperature

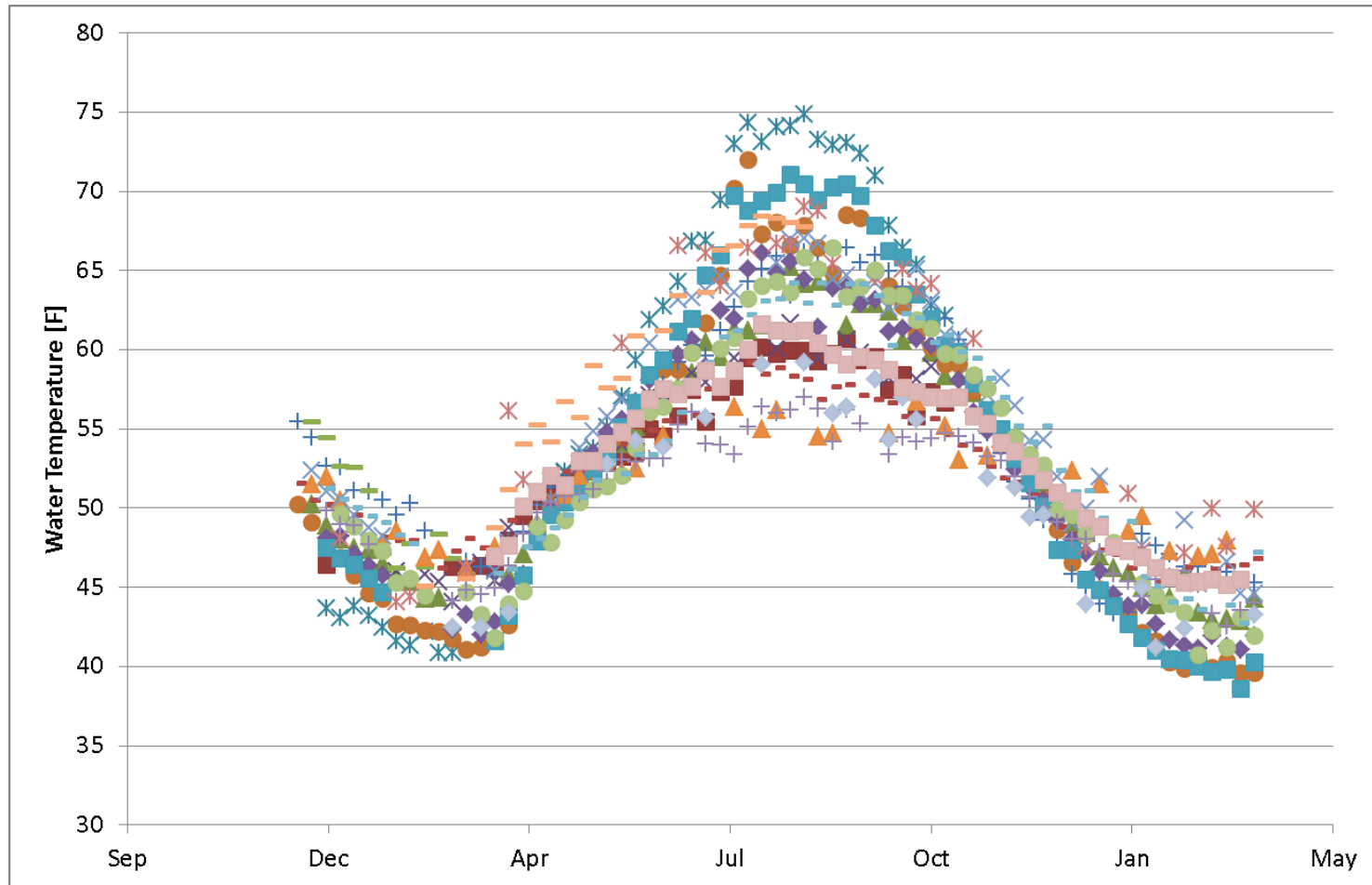

# Seasonal Change in Load

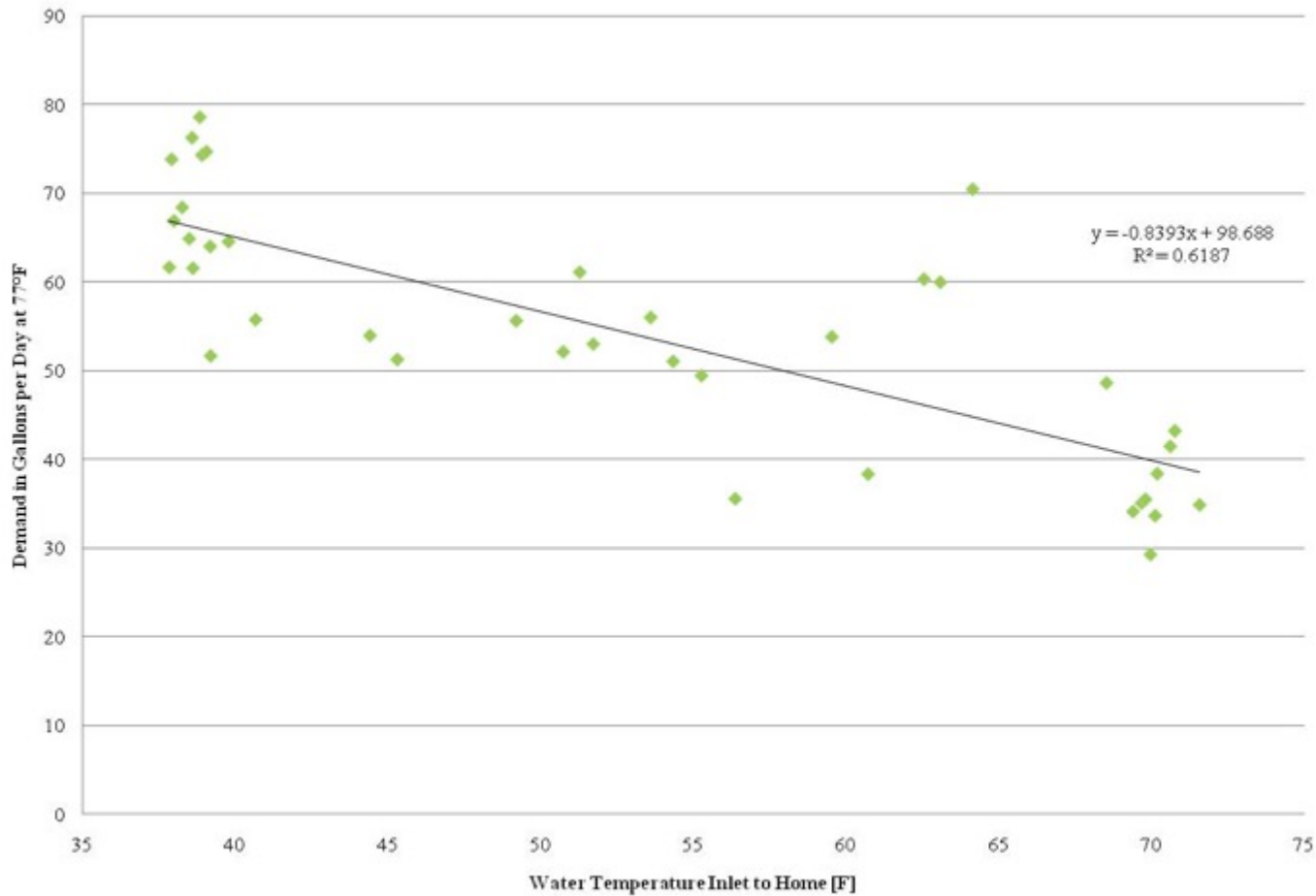



# Support for Water Heating Projects

- Minnesota CARD Grants
  - MN Department of Commerce
  - To identify new technologies or strategies to maximize energy savings, improve the effectiveness of energy conservation programs in order to help utilities to achieve the annual state energy conservation goal of 1.5 percent
- Building America
  - Department of Energy
  - Conducts research to continually develop innovative, cost-effective energy saving solutions—better products, better new homes, better ways to improve older homes, and better buildings in which we work, shop, and lead our everyday lives.